

HR507
7-Mode Hand Shower
Specification Submittal

Location:

Model Numbers

- HR507** 7-Mode HydroMersion® Hand Shower

Options/Modifications

- 15  1.5 gpm (5.7 L/min) flow restrictor
- BBZ Brushed Bronze finish
- MB Matte Black finish
- STN Satin Nickel finish
- L2 Less hand shower

Compliance

- ASME A112.18.1/CSA B125.1.
- Hand shower wand meets ADA requirements for operation.



Feature Highlights

- 4" round 7-mode HydroMersion hand shower wand with Non-Positive Shutoff (NPSO).
- Wall cradle for hand shower wand mounting.
- 60" flexible metal hose.
- Standard 2.0 gpm (7.6 L/min) flow restrictor.
- Shall be metal and nonmetal construction, plated in standard Polished Chrome finish.

Warranty

Limited Lifetime - for residential installations.
10 Years - for commercial/industrial installations.
 Refer to www.symmons.com/warranty for complete warranty information.



SKU Builder

Series	Finish	Modifier	Flow Rate	Final SKU
HR507			15	HR50715
HR507	MB	L2		HR507MBL2

Note: No more than two modifiers (L1-L7) permitted when ordering. Modifiers will list in numerical order.

Architectural/Engineering Specification

Symmons 7-Mode Hand Shower _____ Features 4" round 7-mode HydroMersion hand shower wand with NPSO, wall cradle for hand shower wand mounting, 60" flexible metal hose, and standard 2.0 gpm (7.6 L/min) flow restrictor. Components shall be metal and nonmetal construction, plated in standard Polished Chrome finish. 10-Year Commercial Warranty. ASME A112.18.1/CSA B125.1 compliant. Hand shower wand meets ADA requirements for operation. Available options: 15 = 1.5 gpm (5.7 L/min) flow restrictor, BBZ = Brushed Bronze finish, MB = Matte Black finish, and STN = Satin Nickel finish, and L2 = Less hand shower.

Dimensions

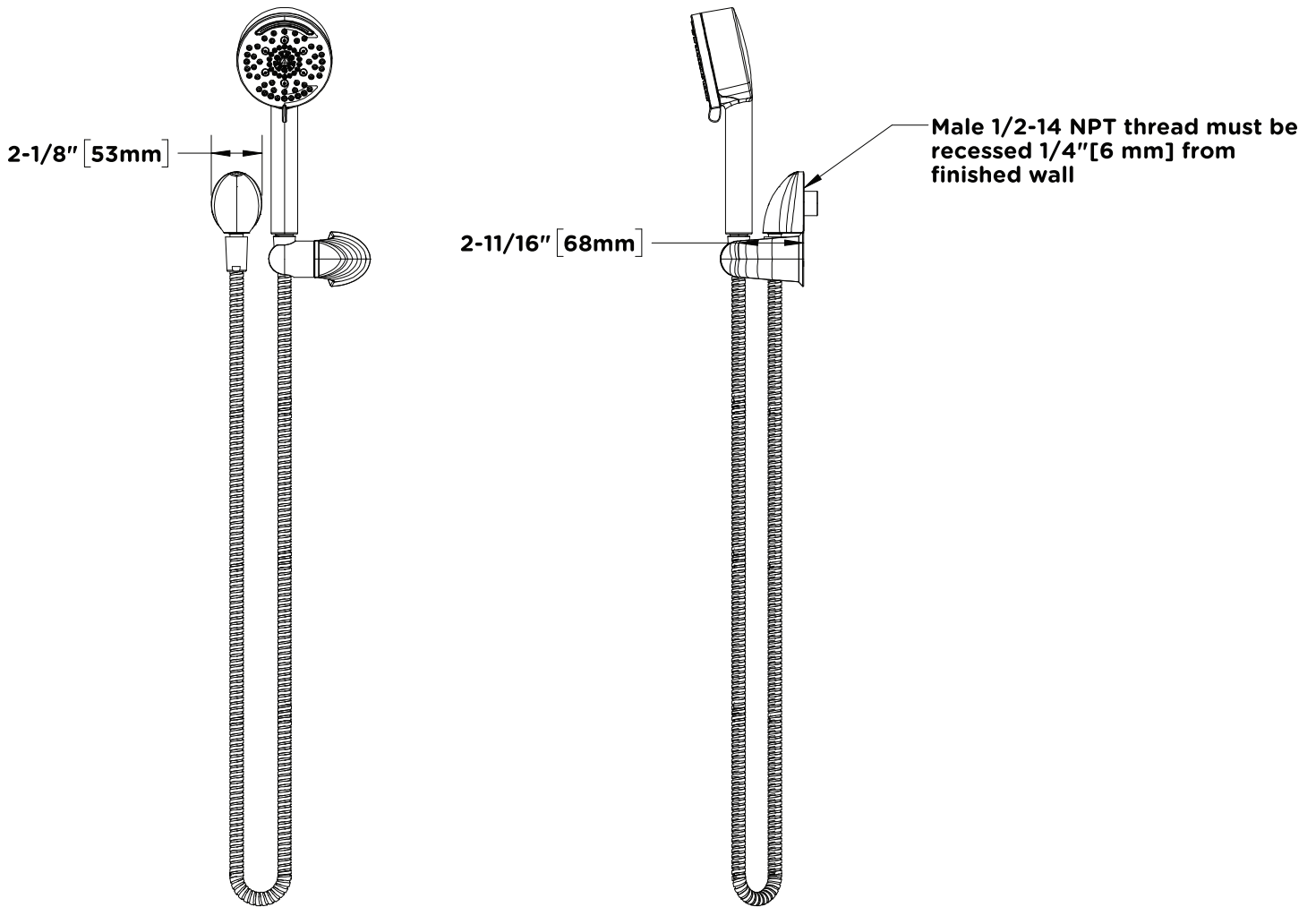

Note: Dimensions are subject to change without notice.