

Location:

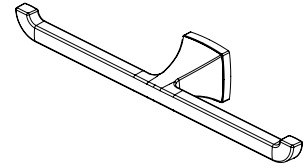

563DTP Double Toilet Paper Holder Specification Submittal

Model Numbers <input type="checkbox"/> 563DTP Double Toilet Paper Holder	Options/Modifications <input type="checkbox"/> STN Satin Nickel finish <input type="checkbox"/> MB Matte Black finish
Feature Highlights <ul style="list-style-type: none">• Metal construction• Standard finish is polished chrome• RA-09132 mounting hardware included	Warranty Limited Lifetime - to the original end purchaser in consumer/residential installations. 10 Years - for commercial/industrial installations. Refer to www.symmons.com/warranty for complete warranty information.

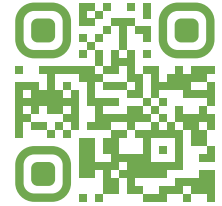

Architectural/Engineering Specification

Symmons _____ Double Toilet Paper Holder includes metal construction, polished chrome standard finish, and RA-09132 mounting hardware. 10 Year Commercial Warranty. Available options: "STN - Satin Nickel finish", and "MB - Matte Black finish".

Dimensions

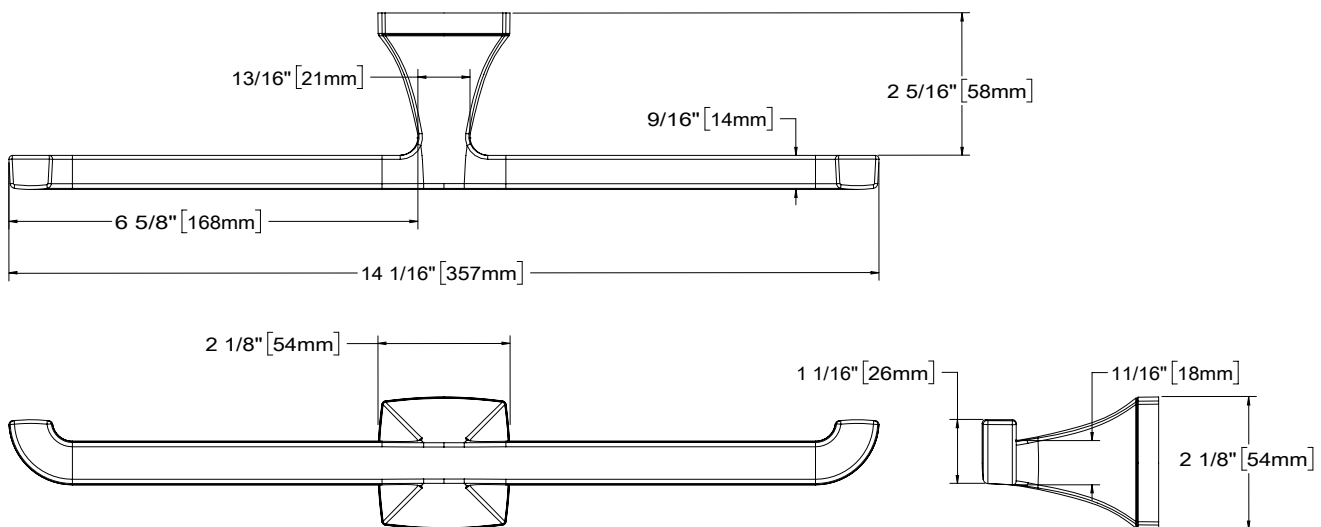

Note:

1) Dimensions subject to change without notice.