

Location:



Toilet Paper Holder CD0171-3DTP

Specification Submittal

Model Numbers

- ☐ CD0171-3DTP Toilet Paper Holder

Finish Options

Append appropriate -suffix to model number.

- Polished chrome (standard)

Feature Highlights

- Metal construction
- Mounting hardware included
- Standard finish is polished chrome

Warranty

- Limited Lifetime - to the original end purchaser in residential/consumer installations.
- 5 years - for commercial installations

Dimensions Toilet Paper Holder, CD0171-3DTP

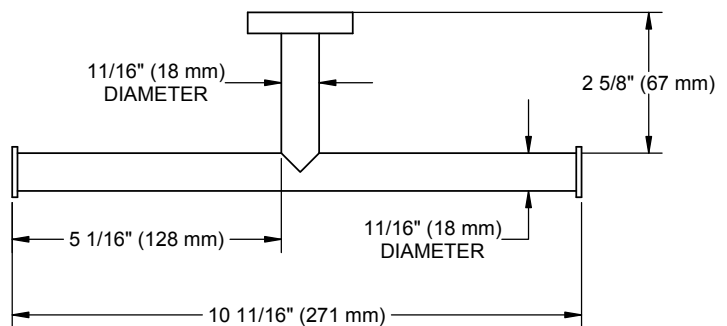
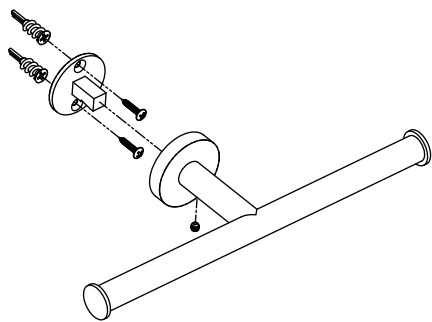

Note: Dimensions subject to change without notice

