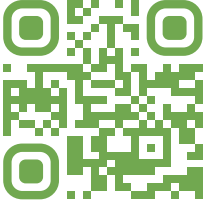

HSA507 Location:
Multifunction Handheld Showerhead
Specification Submittal

Model Numbers	Feature Highlights
<input type="checkbox"/> HSA507 Multifunction Handheld Showerhead	<ul style="list-style-type: none"> • Multifunction hand shower wand with HydroMersion technology for increased pressure and force. • 4" hand shower wand spray head features 7 modes, including Full, Massage, Waterfall, Spa, and Pause. • Non-corrosive EverFlow rubber nozzles are easy to clean. • Shower arm, flange and hand shower wand cradle adaptor included. • 60" flexible metal hose. • Metal, adjustable, hand shower wand cradle. • 2.0 gpm (7.6 L/min) flow rate.
Options/Modifications	
<input type="checkbox"/> 15 1.5 gpm (5.7 L/min) flow restrictor <input type="checkbox"/> L2 Less Hand Shower Wand <input type="checkbox"/> BBZ Brushed Bronze finish <input type="checkbox"/> MB Matte Black finish <input type="checkbox"/> STN Satin Nickel finish Note: Append appropriate suffix to model number.	Warranty
Compliance <ul style="list-style-type: none"> • ASME A112.18.1/CSA B125.1. 	Limited Lifetime - for residential installations. 10 Years - for commercial/industrial installations. Refer to www.symmons.com/warranty for complete warranty information. 

Architectural/Engineering Specification

Symmons HSA507 Shower Arm _____ Features include multifunction hand shower wand with HydroMersion technology for increased pressure and force, 4" hand shower wand spray head features 7 modes, including Full, Massage, Waterfall, Spa, and Pause, non-corrosive EverFlow rubber nozzles are easy to clean, shower arm, flange and hand shower wand cradle adaptor included, 60" flexible metal hose, metal, adjustable, hand shower wand cradle, 2.0 gpm (7.6 L/min) flow rate. 10-Year Commercial Warranty. ASME A112.18.1/CSA B125.1 compliant. Available options: 15 = 1.5 gpm (5.7 L/min) flow restrictor, L2 = Less Hand Shower Wand, BBZ = Brushed Bronze finish, MB = Matte Black finish, and STN = Satin Nickel finish.

Dimensions

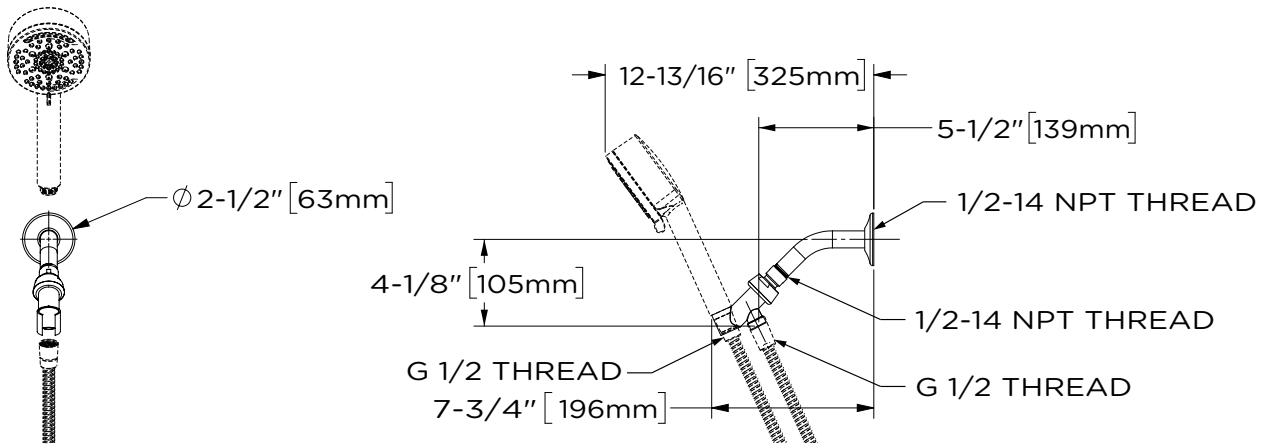

Note:
Dimensions are subject to change without notice.