



SYMMONS

Temptrol Rapid Install™ Bracket RTS-076 Installation Instructions

RECOMMENDED TOOLS



Safety Glasses



Measuring Tape



Drill



Level

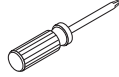

Phillips Screwdriver

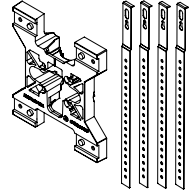

1. VALVE BODY INSTALLATION

1.1 Orient Mounting Bracket and Valve Body

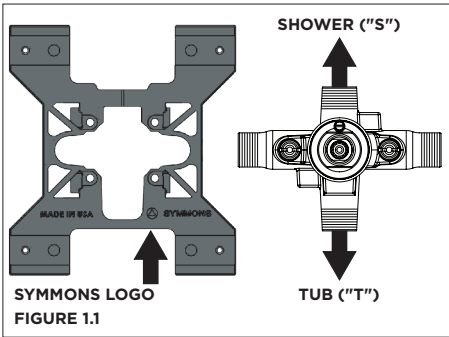

Mounting bracket and valve body **must** be oriented correctly to ensure successful installation (see FIGURE 1.1).

1. Orient valve body so shower outlet ("S") is facing upward and tub outlet ("T") is facing downward.
2. Orient bracket so the Symmons logo is visible in the bottom right corner.

1.2 Install Valve Body to Mounting Bracket

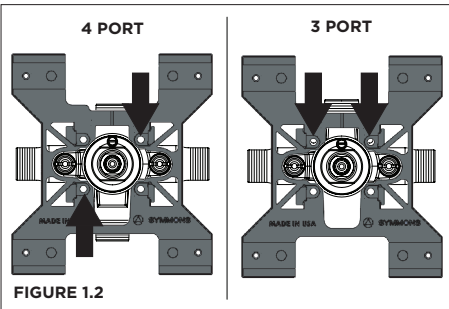

1. Align screw holes in bracket with screw holes in valve body stringer mounts (see FIGURE 1.2):
4 PORT (bottom left & top right holes)
3 PORT (top left & top right holes)
2. Place valve body into mounting bracket. Thread (2x) screws into mounting bracket to secure valve body (see FIGURE 1.3).

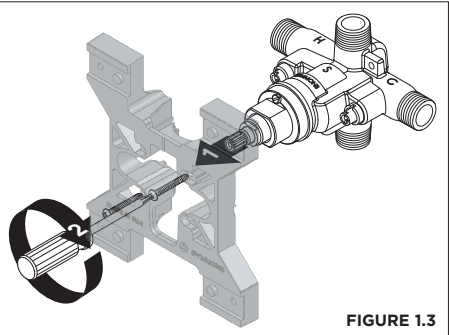

2. MOUNTING BRACKET INSTALLATION

2.1 Metal Straps

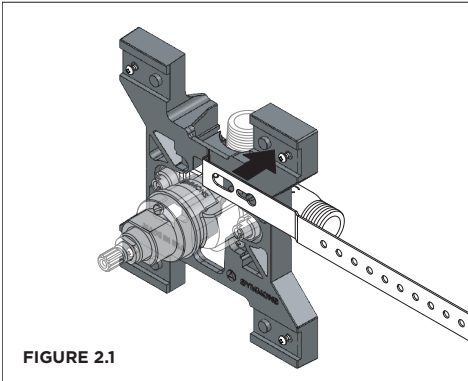

FIGURE 2.1

Bracket is used to secure valve between wall studs up to **24 inches**, center to center. Bracket will fit in minimum **2x3 wall cavity**. Bracket will rough valve at **2-7/8"** from centerline of valve ports to front of finished wall.

1. Place metal straps (x4) over screws. Screws will come preassembled to bracket.
2. Pull metal straps tight against bracket ears. Screws will protrude through small screw hole in metal straps.
3. Drive screws into bracket to secure straps. Use caution not to strip screws.

2.2 Install Bracket

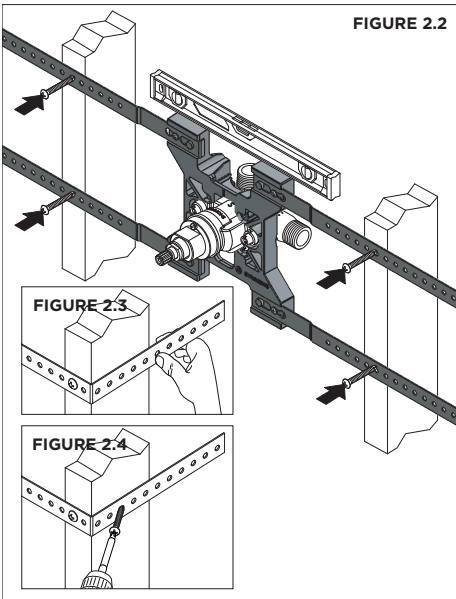
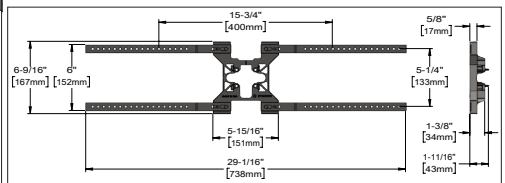

FIGURE 2.2

Mounting bracket will locate valve body in wall cavity at appropriate depth (valve body rough-in is not required).

1. Confirm valve body and mounting bracket are level. Drive (x4) wood screws through metal straps into wood studs (see FIGURE 2.2)
2. Bend excess strap around wood studs. (see FIGURE 2.3)
3. Drive (4x) wood screws, at inward angle, through metal straps into sides of wood studs (see FIGURE 2.4). Installing wood screws at inward angle will pull metal straps tight against wood studs.



⚠ WARNING: This product can expose you to chemicals including lead, which is known to the state of California to cause cancer, birth defects, or other reproductive harm. For more information, go to www.P65Warnings.ca.gov.

Symmons Industries, Inc. ■ 31 Brooks Drive ■ Braintree, MA 02184

Phone: (800) 796-6667 ■ Fax: (800) 961-9621

symmons.com ■ gethelp@symmons.com

Copyright © 2026 Symmons Industries, Inc. ■ 020626