





S23 Series
Kitchen Faucet
Operation & Maintenance Manual



Model S23



Model Numbers	Feature Highlights
<ul style="list-style-type: none"> <input type="checkbox"/> S23 Faucet only <input type="checkbox"/> S231 Faucet with swivel spray aerator in place of hose and spray <input type="checkbox"/> S232 Faucet with hose and spray <input type="checkbox"/> S233 Faucet with hose and spray mounted on escutcheon 	<ul style="list-style-type: none"> • Single lever kitchen faucet with red & blue indicators on handle • Handle limit stops • 8-3/4 inch swing spout with aerator • Ceramic control components • 3/8 inch braided supply lines • Metal construction, polished chrome finish • 1.5 gpm (5.7 L/min) standard flow rate
Compliance	Warranty
<p>- ASME A112.18.1/CSA B125.1</p> <p>- NSF/ANSI/CAN 61: Q<1, NSF/ANSI 372</p> <p></p> <p>⚠ WARNING: This product can expose you to chemicals including lead, which is known to the state of California to cause cancer, birth defects, or other reproductive harm. For more information, go to www.P65Warnings.ca.gov.</p>	<p>Limited Lifetime - to the original end purchaser in consumer/residential installations.</p> <p>10 Years - for commercial/industrial installations. Refer to www.symmons.com/warranty for complete warranty information.</p> 

Dimensions

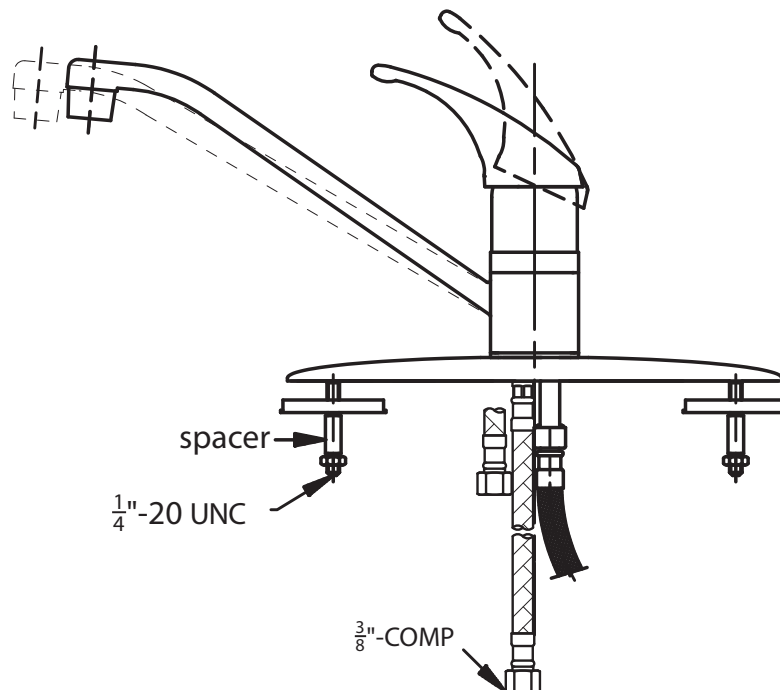

Installation

Caution: Be sure to turn off hot and cold water supplies before installing or servicing faucet.

Step 1 If installing model with hose and spray, install hose guide into hole in sink (normally the far right hole on four hole sink). From underneath sink place washer then nut over hose guide and secure to sink. Insert hose through hose guide and up through middle hole from left in sink. Place gasket on base of escutcheon. From above sink attach hose securely to nipple on base of faucet.

Step 2 Align faucet to sink by matching underside arrow and letter "F" on escutcheon with front of sink. Without straightening copper supplies (if equipped) insert through center hole of sink. Secure faucet to sink by tightening the anchor bar (KN-23), spacer (KN-26) and nut (L-36) on the mounting bolts from underside. (If sink surface is uneven use putty or sealant to make proper seal under base.)

Step 3 Carefully straighten copper supplies (if equipped) to avoid kinking tubing. Connect hot supply to left tube and cold supply to right tube using appropriate connectors.

Step 4 It is very important to thoroughly flush the supply lines to prevent foreign matter, i.e. copper chips, sand, stones, etc. from damaging the sealing surfaces of cartridge. Remove aerator and turn valve handle on to full cold position, open cold supply. Without closing, turn handle to full hot and open hot supply. Let water run in hot only and cold only positions long enough to flush supply lines thoroughly. If equipped with a hose and spray, direct spray head into sink and activate spray. Shut off faucet and replace aerator. Check for leaks.

Step 5 The handle limit stop can be set to limit handle turn to the hot position. The limit mechanism is factory set to allow full handle travel. To adjust the limit stop, turn handle to the full hot position and lift handle to open faucet approximately half way to obtain a smooth flow for correct initial temperature measurement.

Step 6 If when faucet is on and in full hot position and water is too hot, shut water off, remove plug button (KN-157), loosen set screw (L-22) and remove handle (KN-3RB or KN-3BRB), lift limit stop using a small flat head screw driver and rotate clockwise to lower temperature. If water is not hot enough, rotate counter clockwise (See Figure 1 on reverse side). After correct temperature is achieved, reattach handle, reversing procedure above.

Cartridge Replacement (KN-4)

Step 1 Remove plug button (KN-157), loosen set screw (L-22) and remove handle (KN-3RB or KN-3BRB).

Step 2 Engage tabs in cartridge wrench (LN-34) with slots in compression ring (KN-2) and use screwdriver in wrench holes or pliers on wrench and turn counter clockwise until compression ring engages with cap (KN-1). Continue turning counter clockwise so that cap/ring assembly is removed from the body (KN-11).

Step 3 Remove cartridge and o-ring seal (KN-4).

Step 4 Install new cartridge while taking care to maintain position of the o-ring seal at the base of the cartridge. Match posts in base of cartridge with alignment holes in adapter plate during assembly.

Step 5 Reassemble faucet in reverse fashion. Thread cap onto body firmly by hand. Do not use a wrench which may damage the finish. Tighten compression ring (KN-2) finger tight using the wrench (LN-34) then 1/4 to 1/2 turn further. Set hot water limit stop in accordance with installation step 6 above.

Diverter replacement (KN-169)

1. Follow cartridge replacement steps 1 through 5 above.
2. Remove retaining ring (K-44) with 3/8" hex key wrench.
3. Remove diverter and o-ring (K-46).
4. Grease diverter o-ring and install into body.
5. Press diverter into o-ring and body.
6. Replace retaining ring.

Parts Breakdown

K-41/42*	Hand spray and holder	
K-43	Diverter valve	} Repair use only
K-44	Retainer ring	
K-46	O-ring	
KN-1*	Valve cap	
KN-2	Compression ring	
KN-3RB*	Solid Handle	
KN-3BRB*	Loop Handle	
KN-4	Cartridge	
KN-11 ASSY	Supply body assembly with diverter	
KN-11A ASSY	Supply body assembly without diverter	
KN-19A	Spacer	
KN-20	O-ring (2)	
KN-23	Anchor bar (2)	
KN-26	Mounting spacer (2)	
KN-30*	Escutcheon	
KN-30A*	Escutcheon with hand spray hole	
KN-157	Plug button	
KN-169	Diverter assembly	
L-22	Set screw	
L-36	Mounting nut (2)	
LN-216*	Aerator (Faucet with hand spray)	
LN-34	Cartridge wrench	
LN-135	6" lever handle with red/blue indicators	
LN-247	Flex hoses (3/8 inch compression)	

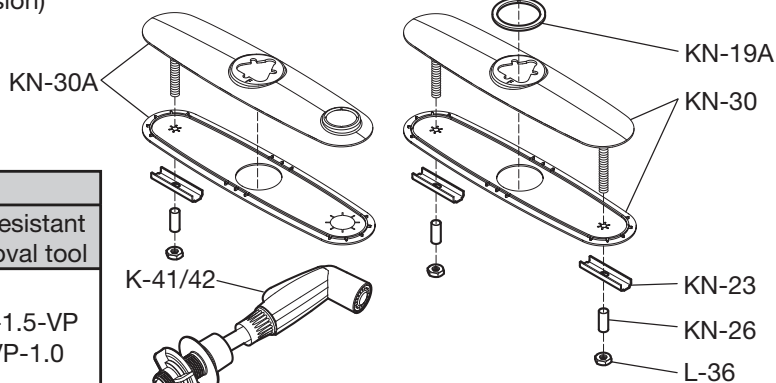
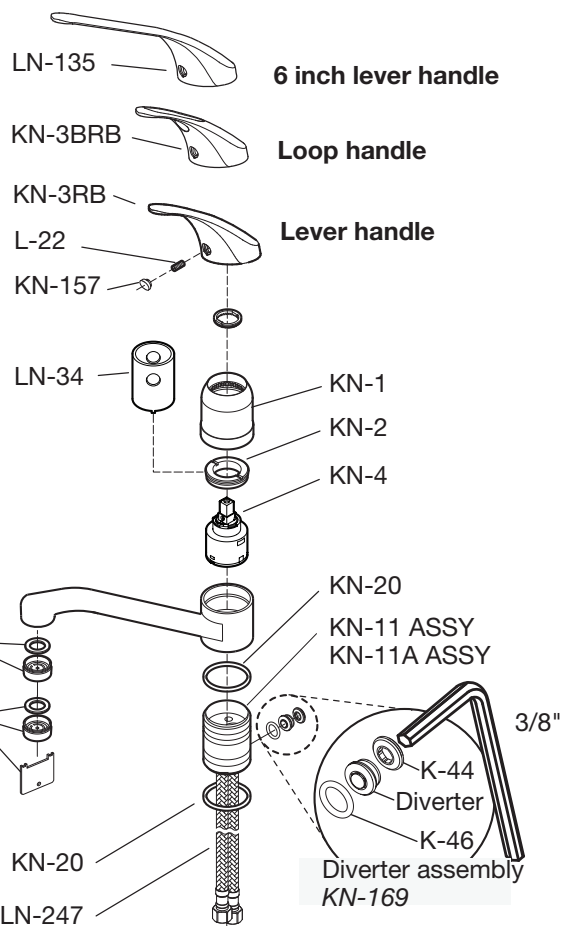
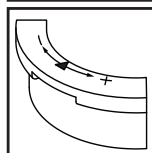
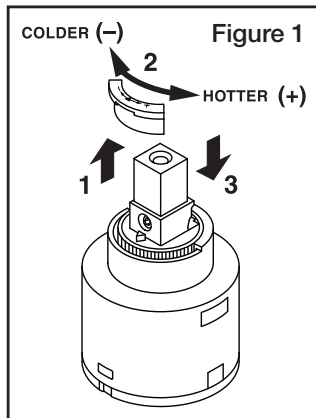

Aerator (flow regulator)	Part Number*	
	Standard Aerator	Vandal Resistant with removal tool
2.2 gpm (8.3L/min)	LN-15	LN-101
1.5 gpm (5.7L/min)	FLR-110-1.5	FLR-110-1.5-VP
1.0 gpm (3.8L/min)	FLR-110-1.0	RL-288-VP-1.0
.5 gpm (1.9L/min)	----	LN-100
Removal tool part number, LL-60K 		

* Note: When ordering parts for products with an optional decorative finish, append appropriate three letter finish suffix code to part numbers marked with an asterisk (*).