



SYMMONS Identity™



SLW6712
Two Handle Widespread Lavatory Faucet
Operation & Maintenance Manual

Model Numbers

- ☐ **SLW6712**
Two Handle Widespread Lavatory Faucet with A Push Pop Drain Assembly

Specification

Two handle widespread lavatory faucet features 8"-16" mount, ceramic cartridges, 1/2" IPS inlet connections, push pop-up drain assembly and standard 1.0 gpm (3.8 L/min) aerator. Faucet constructed from brass, plated in standard polished chrome finish.



Compliance

- ASME A112.18.1/CSA B125.1
- NSF/ANSI/CAN 61: Q<1, NSF/ANSI 372
- WaterSense 1.0 gpm



⚠ WARNING: This product can expose you to chemicals including lead, which is known to the state of California to cause cancer, birth defects, or other reproductive harm. For more information, go to www.P65Warnings.ca.gov.

Warranty

Limited Lifetime - to the original end purchaser in consumer/residential installations.
10 Years - for commercial/industrial installations. Refer to www.symmons.com/warranty for complete warranty information.



Dimensions

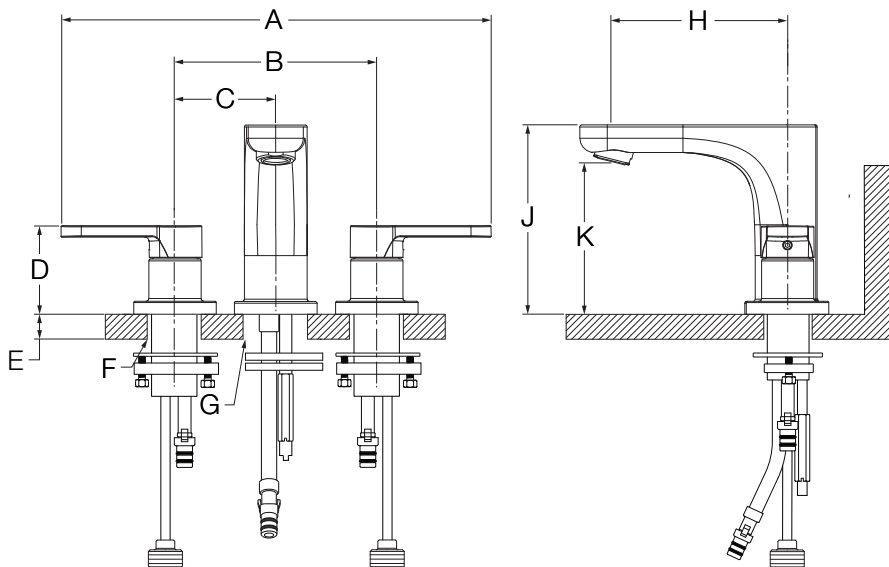

Measurements	
A	13-1/2", 343 mm
B	8", 203 mm
C	4", 102 mm
D	(2x) 2-1/8", 54 mm
E	Deck Thickness Ref. Min. 5/8", 16 mm Max. 1-3/8", 35 mm
F	(2x) Hole Size Min. Ø 1-1/4", 32 mm Max. Ø 1-1/2", 38 mm
G	Hole Size Min. Ø 1-3/8", 35 mm Max. Ø 1-5/8", 41 mm
H	4-5/16", 110 mm
J	4-5/8", 117 mm
K	3-5/8", 92 mm

Note: Dimensions subject to change without notice.

Parts Breakdown

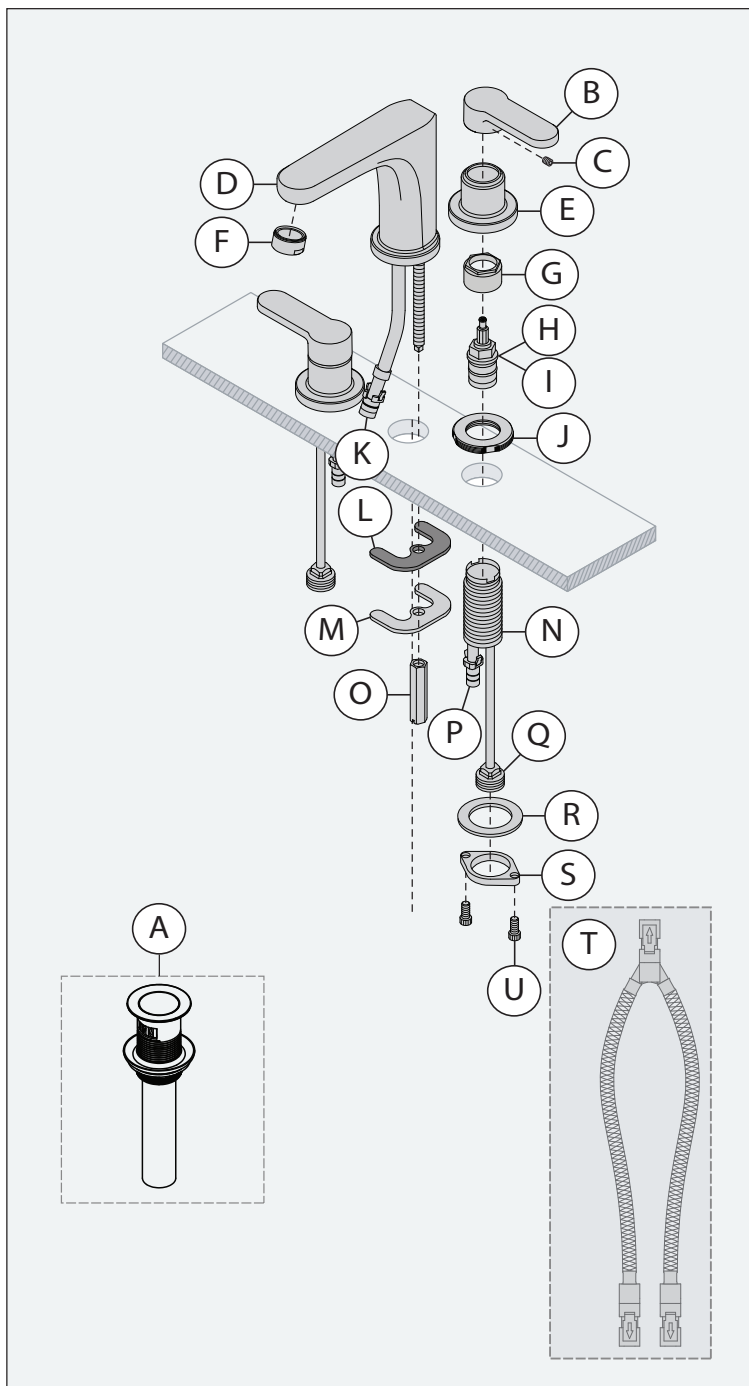

Replacement Parts		
Item	Description	Part Number
A	Push Pop Drain Assembly	RL324*
B	Handle	RL-287*
C	Set Screw	
F	Aerator Kit (2.2)	LN-15*
	Aerator Kit (1.5)	FLR-110-1.5*
	Aerator Kit (1.0)	FLR-110-1.0*
	Laminar Flow Kit (2.2)	RL-019-2.2*
	Laminar Flow Kit (1.5)	RL-019-1.5*
	Laminar Flow Kit (1.0)	RL-019-1.0*
	Laminar Flow Kit (0.5)	RL-019*
	Vandal Proof Kit (2.2)	RL-315-2.2*
Vandal Proof Kit (1.5)	RL-315-1.5*	
Vandal Proof Kit (1.0)	RL-315-1.0*	
Vandal Proof Kit (0.5)	RL-315-0.5*	
H	Hot Cartridge	RL-075
I	Cold Cartridge	RL-076
L M O	Mounting Hardware, Spout	RL-123
R S U	Mounting Hardware, Valve Body	RL-211

***Note:** Append -STN to part number for Satin Nickel finish.

Tools Required	
Adjustable Wrench	
Allen Wrench (3/32")	
Plumber Putty	
Plumber Tape	

If replacing an older faucet ensure water supply is turned OFF before removing, then turn faucet control valve ON to relieve water pressure.

DO NOT use pipe dope or thread sealant on drain assembly, or any plastic threaded components.

Installation

- 1) **Push Pop Install:** Insert drain body (L) into drain opening. From below, Tighten locking nut (O) with gasket (M) and washer (N) to flange. Tighten tail nut (Y) with washer (X) to secure tail pipe (Q). **DO NOT** overtighten.

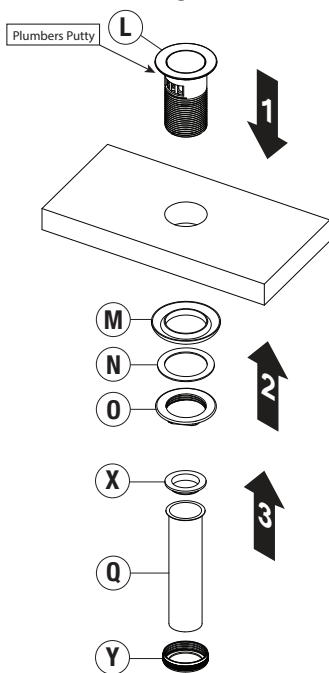

- 2) Insert valve bodies (N) through sink holes.

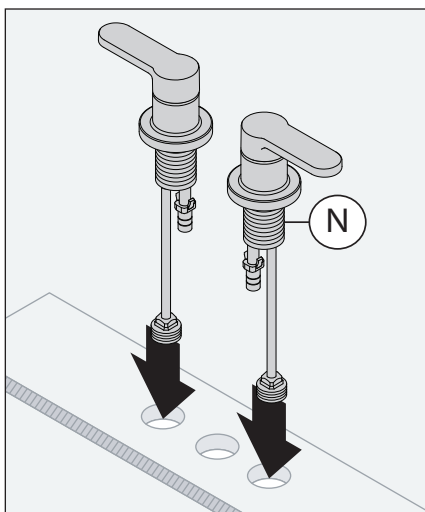

- 3) Install washer (R) and mounting nut (S) to valve body (N). Secure with screws (U).

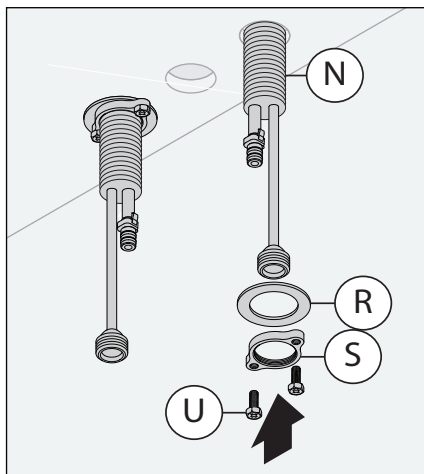

- 4) Insert spout body (D) through sink hole. Attach rubber washer (L) and metal washer (M) to threaded rod on spout body. Secure with mounting nut (O).

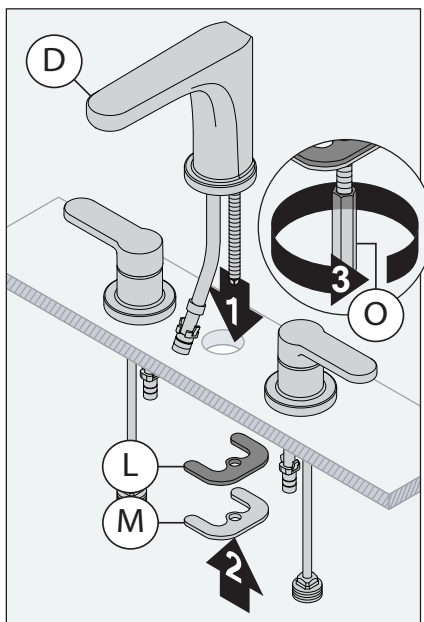

- 5) Connect hoses (T) to spout and valve body water connections (K and P).

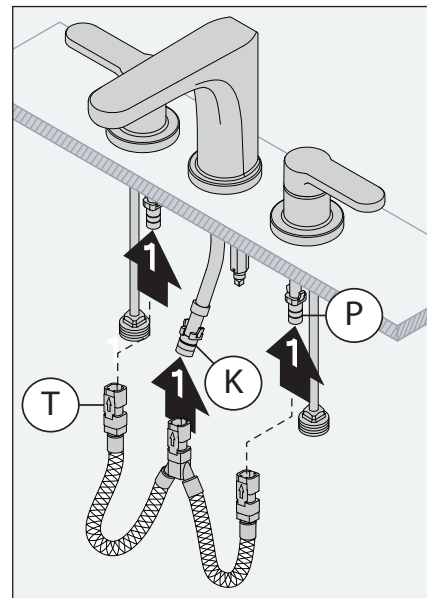

- 6) Using a wrench, attach supply lines to IPS inlet connections (Q) and shut off valves. **DO NOT** overtighten.

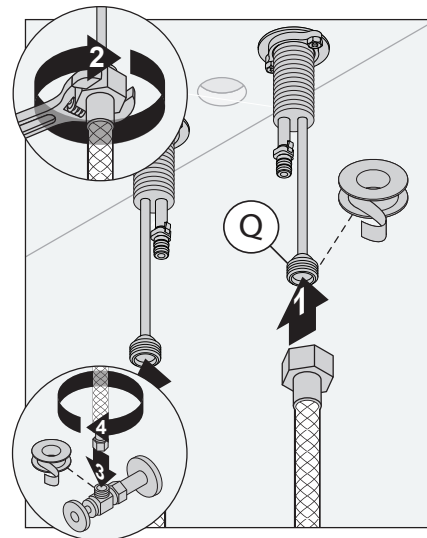

- 7) Turn on water supplies. Remove aerator (F) and flush lines free of debris. Check for leaks.

Maintenance

1) Turn off water supply. Loosen and remove the handle set screw (C) and handle (B).

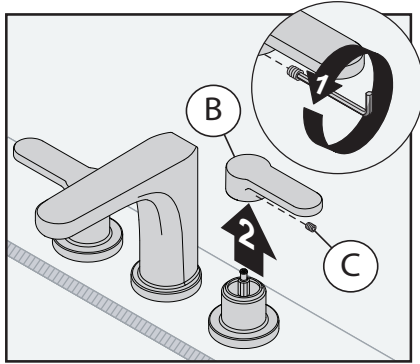

2) Remove escutcheon (E) and nut (G).

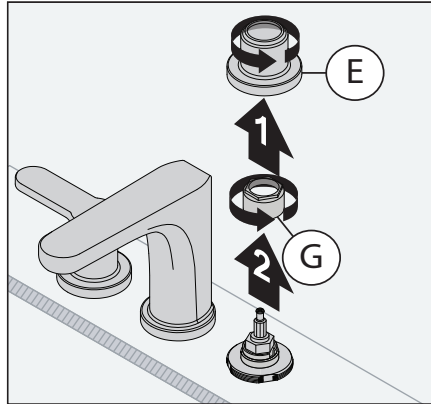

3) Remove cartridge (H and/or I) and inspect for debris. Replace cartridge if necessary.

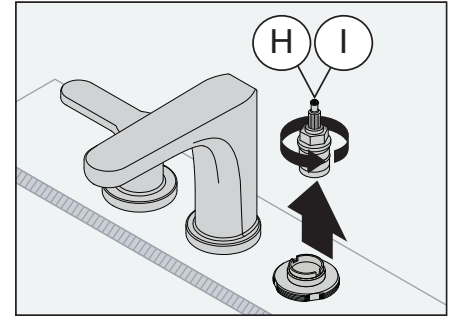

4) Install cartridge following steps 1 & 2 in reverse.

Troubleshooting Chart

Problem	Cause	Solution
Finish is spotting.	Elements in water supply may cause water staining on finish.	Clean finished trim area with a soft cloth using mild soap and water or a non-abrasive cleaner and then quickly rinse with water.



SLW6712
Grifo de batería para lavabo con dos manijas
Manual de funcionamiento y mantenimiento

Números de modelo

- SLW6712**
Grifo de batería para lavabo con dos manijas con un ensamblaje de drenaje de empuje

Especificación

El grifo de batería para lavabo con dos manijas presenta un montaje de 8"-16 e incluye cartuchos cerámicos, conexiones de entrada IPS de 1/2", empuje el conjunto de drenaje emergente y aireador estándar de 1.0 gpm (3.8 L/min). Grifo hecho de latón, con acabado de chapado de cromo pulido estándar.



Cumplimiento

-ASME A112.18.1/CSA B125.1

-NSF/ANSI/CAN 61: Q<1, NSF/ANSI 372

-WaterSense 1.0 gpm



⚠ WARNING: Este producto puede exponerlo a productos químicos, incluido el plomo, que es conocido por el estado de California para causar cáncer, defectos de nacimiento u otro daño reproductivo. Para obtener más información, visite www.p65warnings.ca.gov.

La Garantía

Vida Útil Limitada - Hasta el comprador final original en instalaciones residenciales/de consumo.

10 Años - Para instalaciones comerciales/industriales. Consulte www.symmons.com/warranty para obtener

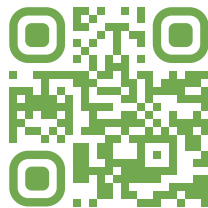

Dimensiones

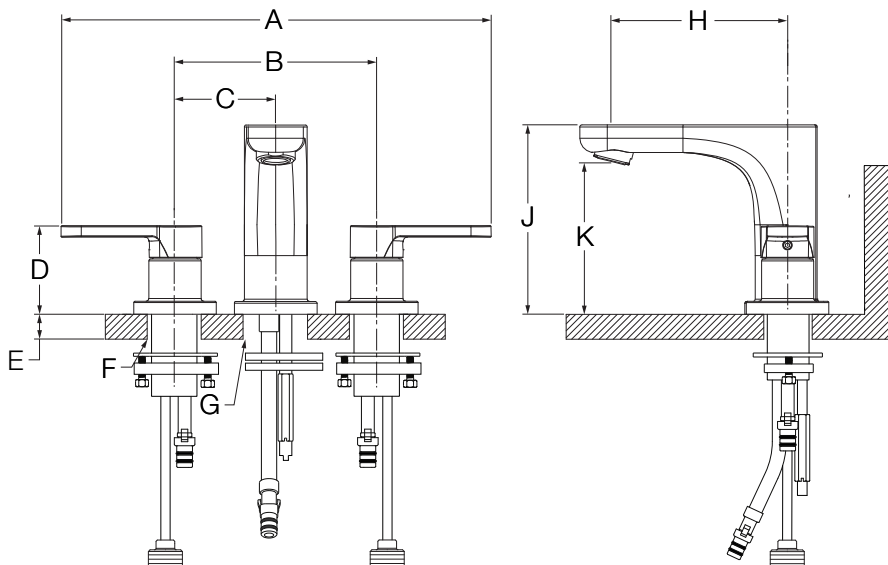

Medidas	
A	13-1/2", 343 mm
B	8", 203 mm
C	4", 102 mm
D	(2x) 2-1/8", 54 mm
E	Referencia del grosor de la cubierta Mín. 5/8", 16 mm Máx. 1-3/8", 35 mm
F	Tamaño del orificio (2x) Mín. Ø 1-1/4", 32 mm Máx. Ø 1-1/2", 38 mm
G	Tamaño del orificio Mín. Ø 1-3/8", 35 mm Máx. Ø 1-5/8", 41 mm
H	4-5/16", 110 mm
J	4-5/8", 117 mm
K	3-5/8", 92 mm

Nota: Las dimensiones están sujetas a cambios sin previo aviso.

Desglose de las piezas

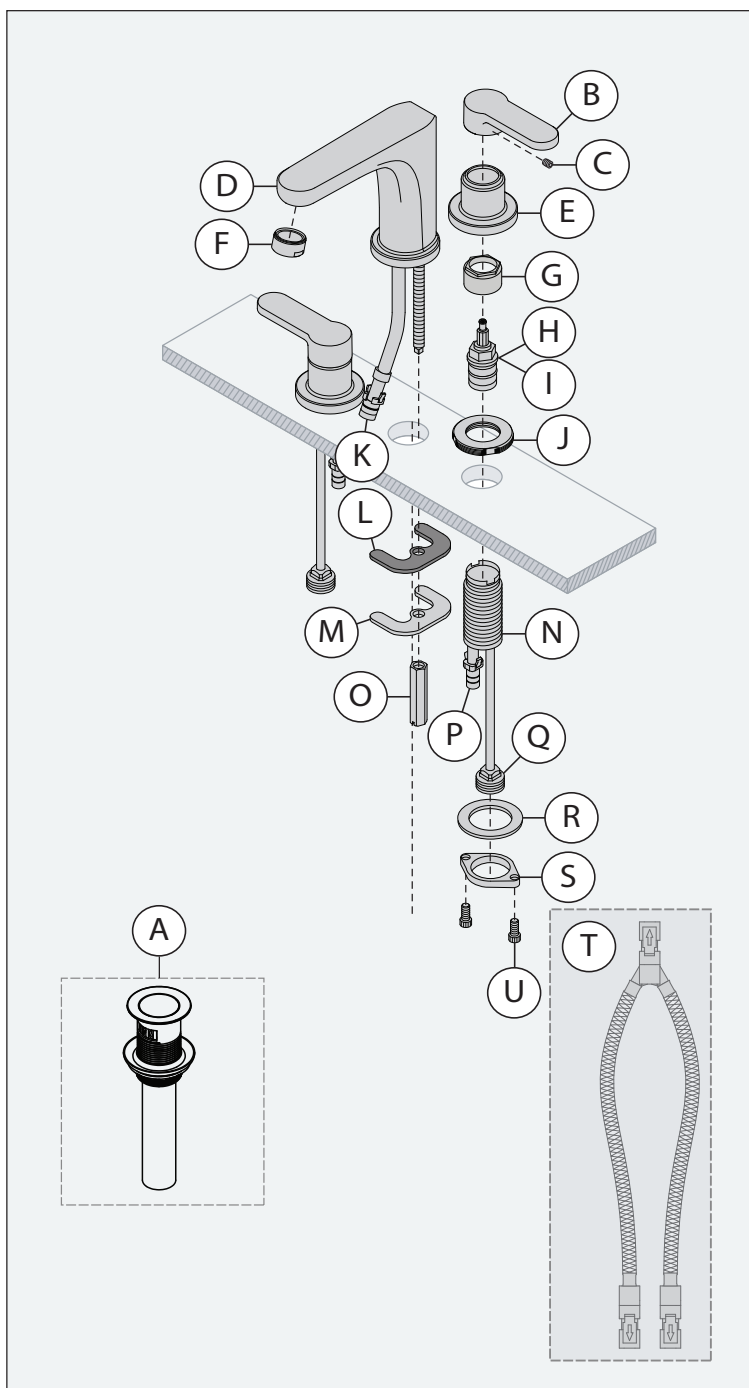

Si está reemplazando otro grifo, asegúrese de que el suministro de agua esté CERRADO antes de quitarlo, luego ABRA la válvula de control del grifo para liberar la presión de agua.



NO utilice la pegamento para tuberías o el sello del hilo en el ensamble de drenaje, o cualquier componente plástico roscado.

Repuestos

Artículo	Descripción	Número de la pieza
A	Montaje de drenaje de empuje	RL324*
B	Manija	RL-287*
C	Tornillo de presión	
F	Juego de aireadores (2.2)	LN-15*
	Juego de aireadores (1.5)	FLR-110-1.5*
	Juego de aireadores (1.0)	FLR-110-1.0*
	Juego de flujo laminar (2.2)	RL-019-2.2*
	Juego de flujo laminar (1.5)	RL-019-1.5*
	Juego de flujo laminar (1.0)	RL-019-1.0*
	Juego de flujo laminar (0.5)	RL-019*
	Resistente al vandalismo (2.2)	RL-315-2.2*
Resistente al vandalismo (1.5)	RL-315-1.5*	
Resistente al vandalismo (1.0)	RL-315-1.0*	
Resistente al vandalismo (0.5)	RL-315-0.5*	
H	Cartucho para agua caliente	RL-075
I	Cartucho para agua fría	RL-076
L	Pieza de montaje, surtidor	RL-123
M		
O		
R	Pieza de montaje, cuerpo de válvula	RL-211
S		
U		

*Nota: Anexar -STN al número de pieza para el acabado de níquel satinado.

Herramientas necesarias

Llave inglesa	
Llave Allen (3/32")	
Masilla de plomero	
Cinta de teflón	

Instalación

- 1) **Push Pop Instalar:** Inserte el cuerpo de drenaje (L) en la abertura de drenaje. Desde abajo, apriete la tuerca de bloqueo (o) con junta (m) y lavadora (n) para brillar. Apriete la tuerca de la cola (y) con lavadora (x) para asegurar el tubo de cola (Q).

NOT revolotee.

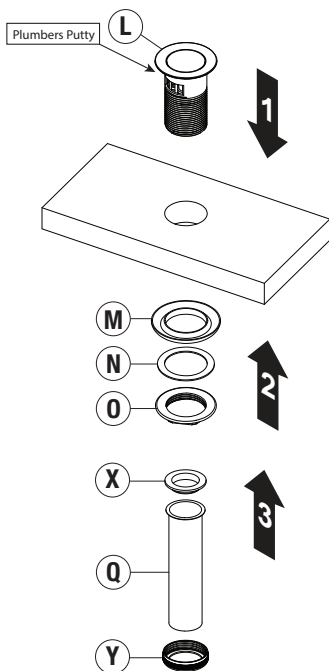

- 2) Inserte los cuerpos de las válvulas (N) a través de los orificios del lavabo.

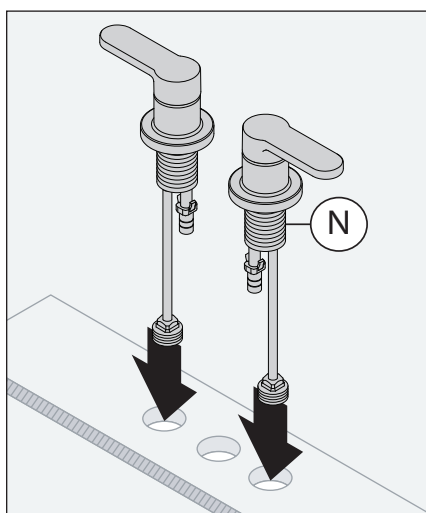

- 3) Instale la arandela (R) y la tuerca de ensamble (S) en el cuerpo de la válvula (N). Sujétela con tornillos (U).

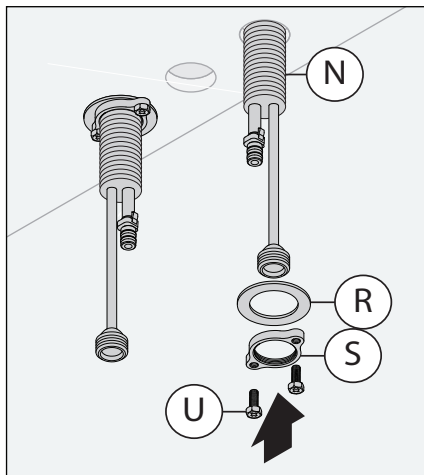

- 4) Inserte el cuerpo del surtidor (D) a través del orificio del lavabo. Conecte la arandela de goma (L) y la arandela de metal (M) la varilla enroscada en el cuerpo del surtidor. Asegure con la tuerca de ensamble (O).

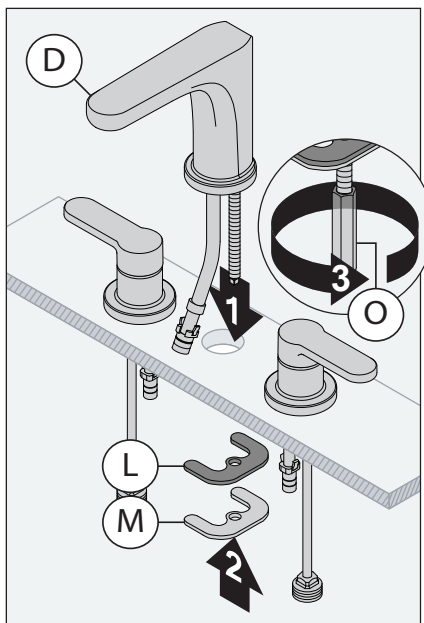

- 5) Conecte las mangueras (T) a las salidas de unión del surtidor y el cuerpo de la válvula (K y P).

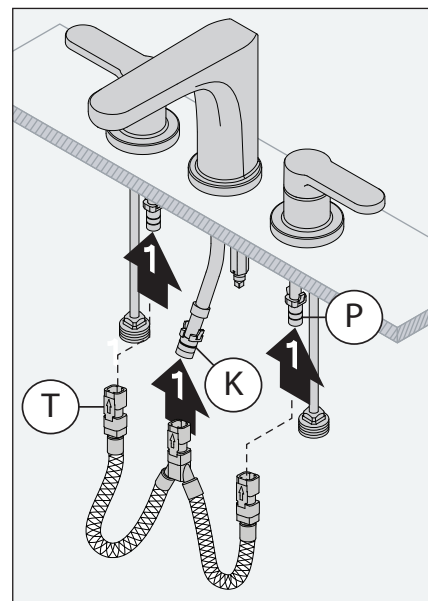

- 6) Con una llave, conecte las líneas de suministro a las conexiones de entrada IPS (Q) y cierre las válvulas. **NO** apriete demasiado.

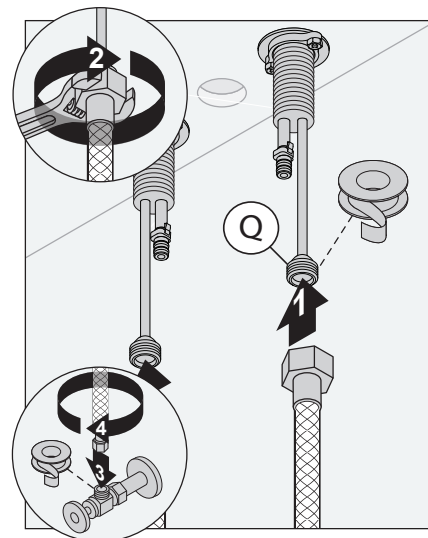

- 7) Abra el suministro de agua. Extraiga el aireador (F) y enjuague las líneas para que queden libres de desechos. Verifique si hay pérdidas.

Mantenimiento

1) Cierre el suministro de agua. Afloje y retire el tornillo de presión de la manija (C) y la manija (B).

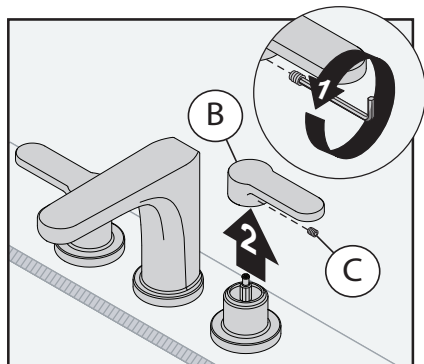

2) Retire el escudete (E) y la tuerca (G).

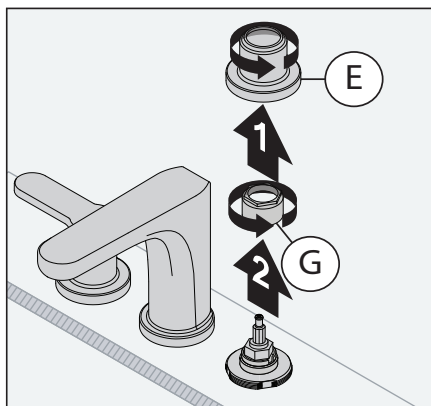

3) Retire el cartucho (H y/o I) e inspecciónelo para detectar residuos. Cambie el cartucho si es necesario.

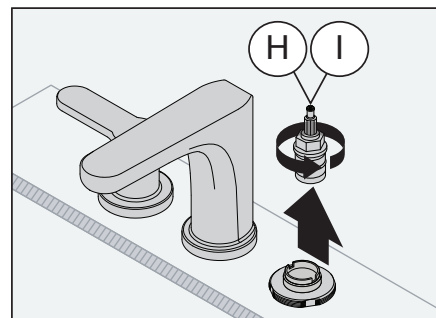

4) Instale el cartucho siguiendo los pasos 1 y 2 en sentido inverso.

Tabla de resolución de problemas

Problema	Causa	Solución
El acabado se está manchando.	Las partículas en el suministro de agua pueden provocar que el agua manche el acabado.	Limpie el área del acabado utilizando un paño suave, jabón neutro y agua, o con un limpiador no abrasivo y luego enjuague rápidamente con agua.



SLW6712
Robinet de salle de bain évasé à deux poignées
Manuel d'utilisation et d'entretien

Numéros de modèle

- **SLW6712**
Robinet de salle de bain évasé à deux poignées avec un ensemble de drainage Push Pop

Spécifications

Le robinet de salle de bain évasé à deux poignées présente une configuration de fixation de 8-16 po et comprend des cartouches en céramique, des raccords d'entrée IPS de 1/2 po, un ensemble de drainage pop-up poussoir et un aérateur standard de 1,0 gpm (3,8 L/min). Le robinet est fait de laiton, au fini chrome poli standard.



Conformité

- ASME A112.18.1/CSA B125.1
- NSF/ANSI/CAN 61: Q<1, NSF/ANSI 372
- WaterSense 1.0 gpm



⚠ ATTENTION: Ce produit peut vous exposer à des produits chimiques, y compris le plomb, qui est connu à l'État de Californie pour provoquer un cancer, des malformations congénitales ou d'autres dommages reproductifs. Pour plus d'informations, rendez-vous sur www.p65warnings.ca.gov.

Garantie

Garantie limitée - à l'acheteur original dans les installations du consommateur/résidentiel.
10 Ans - pour les installations commerciales/industriel. Se reporter au www.symmons.com/warranty pour l'information complète concernant la garantie.



Dimensions

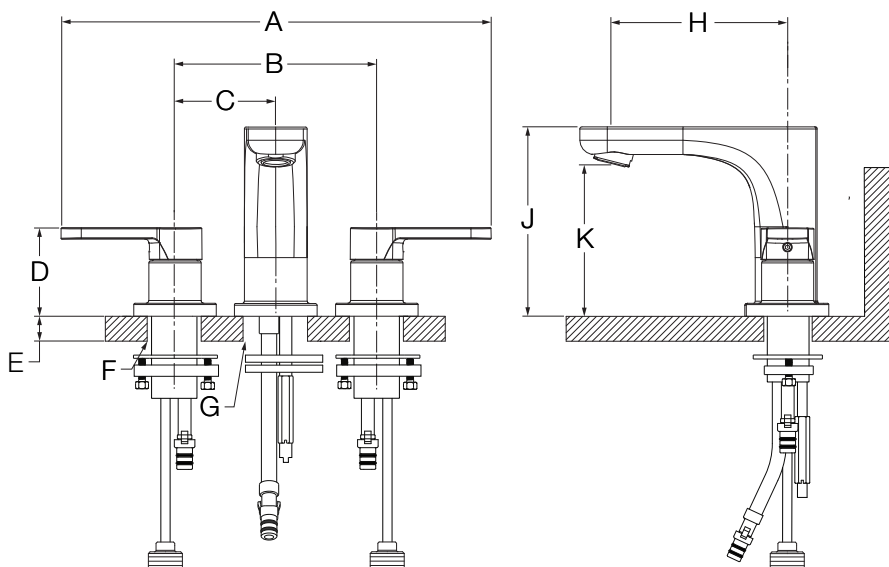

Mesures	
A	13-1/2 po, 343 mm
B	8 po, 203 mm
C	4 po, 102 mm
D	(2x) 2-1/8 po, 54 mm
E	Épaisseur de référence du comptoir Min. 5/8 po, 16 mm Max. 1-3/8 po, 35 mm
F	(2x) Taille du trou Min. Ø 1-1/4 po, 32 mm Max. Ø 1-1/2 po, 38 mm
G	Taille du trou Min. Ø 1-3/8 po, 35 mm Max. Ø 1-5/8 po, 41 mm
H	4-5/16 po, 110 mm
J	4-5/8 po, 117 mm
K	3-5/8po, 92 mm

Remarque : Les dimensions sont sujettes à changer sans préavis.

Liste des pièces

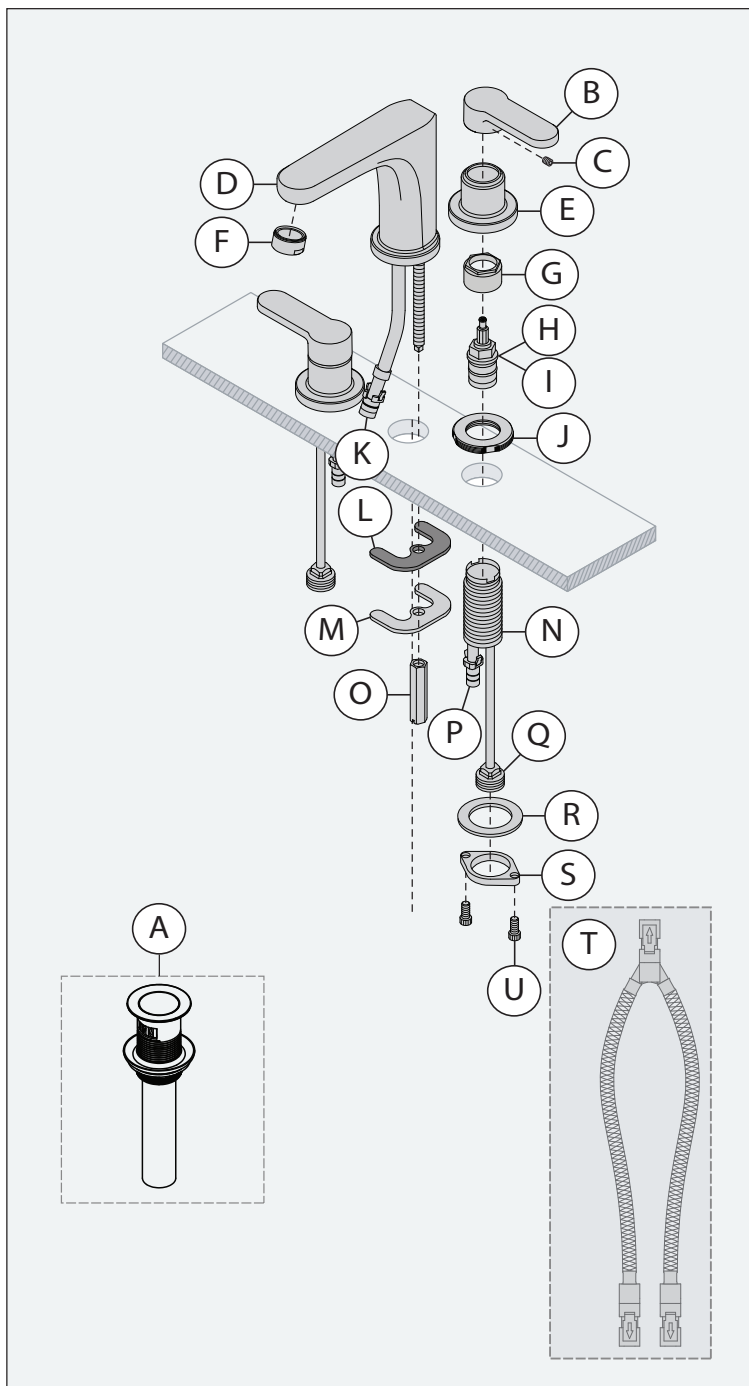

En cas de remplacement d'un ancien robinet, s'assurer que l'alimentation en eau est **COUPÉE** avant de l'enlever, puis **OUVRI**R le robinet pour faire retomber la pression de l'eau.



NE pas utiliser de pâte à joint ou de joint de filetage sur l'ensemble de vidange, ou tout composant fileté en plastique.

Pièces de rechange

Article	Description	Numéro de pièce
A	Ensemble de vidanges PUSH POP	RL324*
B C	Assemblage Vis de pression	RL-287*
F	Trousse de l'aérateur (2,2) Trousse de l'aérateur (1,5) Trousse de l'aérateur (1,0) Trousse de flot laminaire (2,2) Trousse de flot laminaire (1,5) Trousse de flot laminaire (1,0) Trousse de flot laminaire (0,5) Résistant au vandalisme (2,2) Résistant au vandalisme (1,5) Résistant au vandalisme (1,0) Résistant au vandalisme (0,5)	LN-15* FLR-110-1.5* FLR-110-1.0* RL-019-2.2* RL-019-1.5* RL-019-1.0* RL-019* RL-315-2.2* RL-315-1.5* RL-315-1.0* RL-315-0.5*
H	Cartouche d'eau chaude	RL-075
I	Cartouche d'eau froide	RL-076
L M O	Quincaillerie pour la fixation, Bec	RL-123
R S U	Pièces de montage, Corps de vanne	RL-211

*Remarque : Juxtaposer le -STN au numéro de pièce pour le fini Nickel satiné.

Outils requis

Clef ajustable	
Clef Allen (3/32 po)	
Mastic de plombier	
Ruban de plombier	

Installation

- 1) **Installation de Push Pop:** Insérer le corps de drain (L) dans l'ouverture de drain. D'en bas, serrez l'écrou de verrouillage (O) avec le joint (m) et la rondelle (n) pour briller. Serrez le noix de queue (Y) avec une laveuse (X) pour fixer le tuyau de queue (Q).

NE PAS trop serrer.

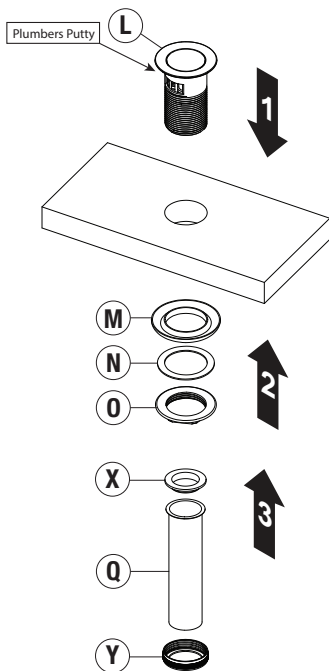

- 2) Insérez les corps de vanne (N) à travers les trous de l'évier.

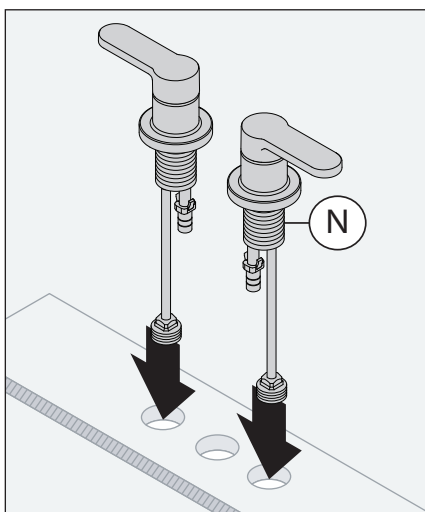

- 3) Installez la rondelle (R) et l'écrou de montage (S) au corps de vanne (N). Fixez avec des vis (U).

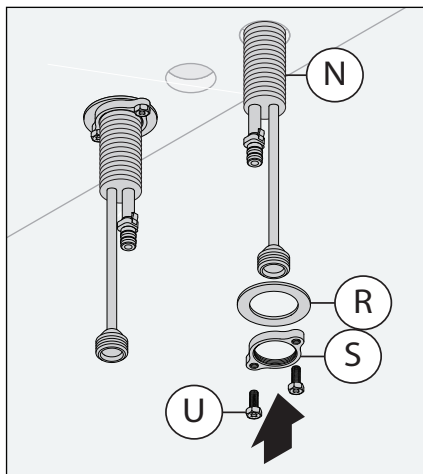

- 4) Insérez le corps du bec (D) à travers le trou de l'évier. Fixez la rondelle en caoutchouc (L) et la rondelle en métal (M) à la tige filetée sur le corps du bec. Fixez avec l'écrou de montage (O).

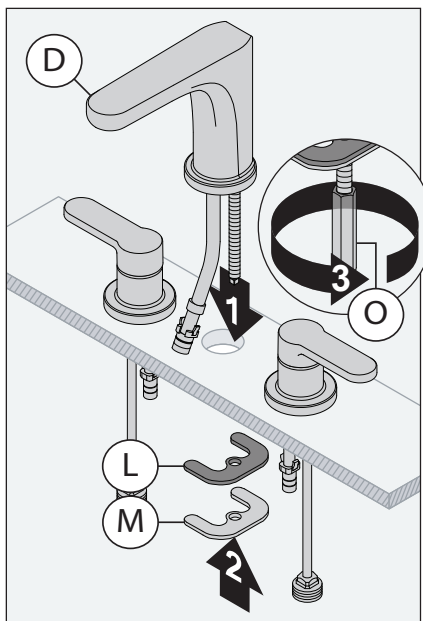

- 5) Branchez les boyaux (T) au bec et aux conduites d'alimentation en eau du corps de vanne (K et P).

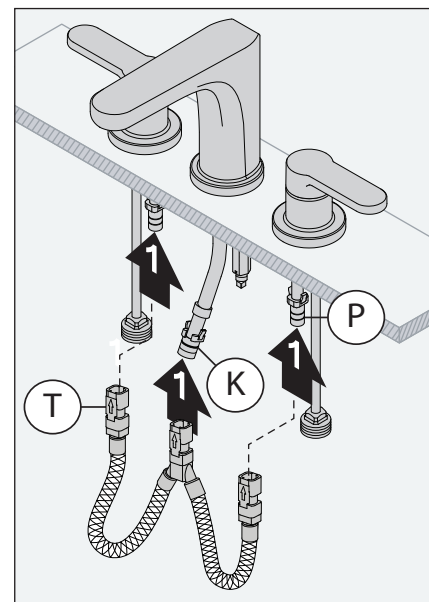

- 6) À l'aide d'une clé, enfoncez les conduites d'alimentation sur les raccords d'entrée IPS (Q) et aux vannes de fermeture. **NE PAS** visser trop fort.

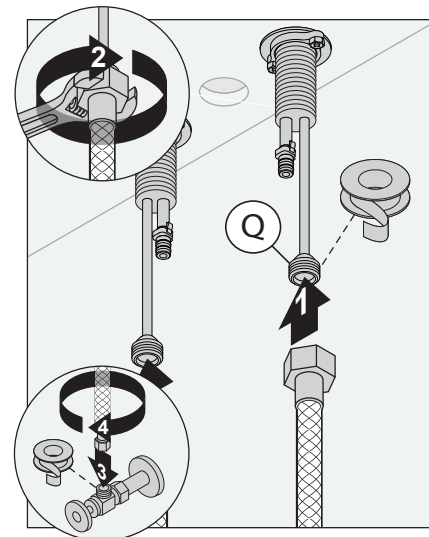

- 7) Allumez l'approvisionnement en eau. Enlevez l'aérateur (F) et rincez les conduites de tout débris. Vérifier pour déceler les fuites.

Entretien

- 1) Couper l'alimentation en eau chaude.
Desserrer et enlever la vis de pression de la poignée (C) et la poignée (B).

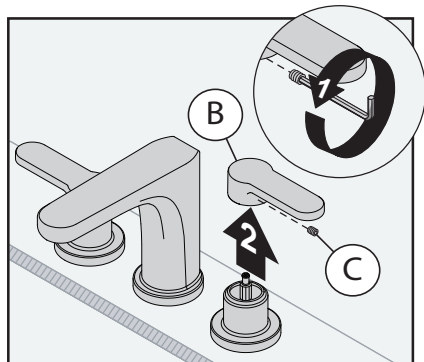

- 2) Retirer la rosace (E) et l'écrou (G).

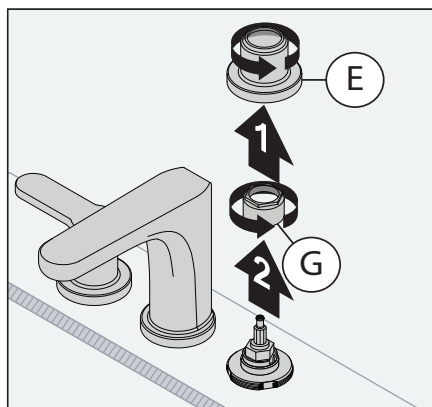

- 3) Retirer et inspecter la cartouche (H et/ou I) afin de détecter la présence de débris. Remplacer la cartouche au besoin.

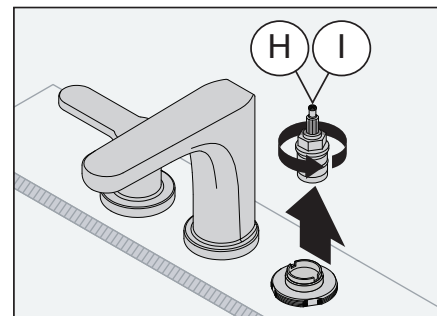

- 4) Installer la cartouche en exécutant les étapes 1 et 2 en ordre inverse.

Tableau de résolution des problèmes

Symptôme	Cause	Solution
Le fini est tâché.	Les éléments présents dans l'eau peuvent causer des tâches sur le fini.	Nettoyer la zone avec un chiffon doux en employant de l'eau et du détergent doux ou un nettoyeur non abrasif et rincer rapidement à l'eau.